

A Low Noise Microphone Preamp with a Phantom Power Option

by Walt Jung and Adolfo Garcia

INTRODUCTION

A preferred method of amplifying low level audio signals from balanced sources is by the use of an *instrumentation amplifier* preamp stage. The instrumentation amplifier, in IC or other form, is configured for gain with just one user adjustable resistor. Allowing transformerless gain, it features maximum rejection of common-mode (CM) noises such as hum, and has low operating noise with commonly used microphones by virtue of a low noise input stage. In performance terms, this translates to an amplifier input referred noise of less than $1 \text{ nV}/\sqrt{\text{Hz}}$ from the circuit or device used, over a working range of gains of 2 to 2000 times (6 dB to 66 dB), while rejecting CM noise signals 90 dB or more. With design

options exercised, such amplifiers can also provide gains of 70 dB or greater.

But, while low noise and distortion are very important, they are by no means the entire requirement. For example, with the use of microphone phantom powering¹ where CM 48 V dc power is fed to a remote microphone capsule, the received audio signal from the microphone must be amplified cleanly without side effects from the dc. In the steady state this is no great problem, but switching transients from the dc feed can wreak havoc with amplifier input stages if care is not taken. Consequently, amplifiers must be protected against power surges, while still operating with little or no sonic degradation.

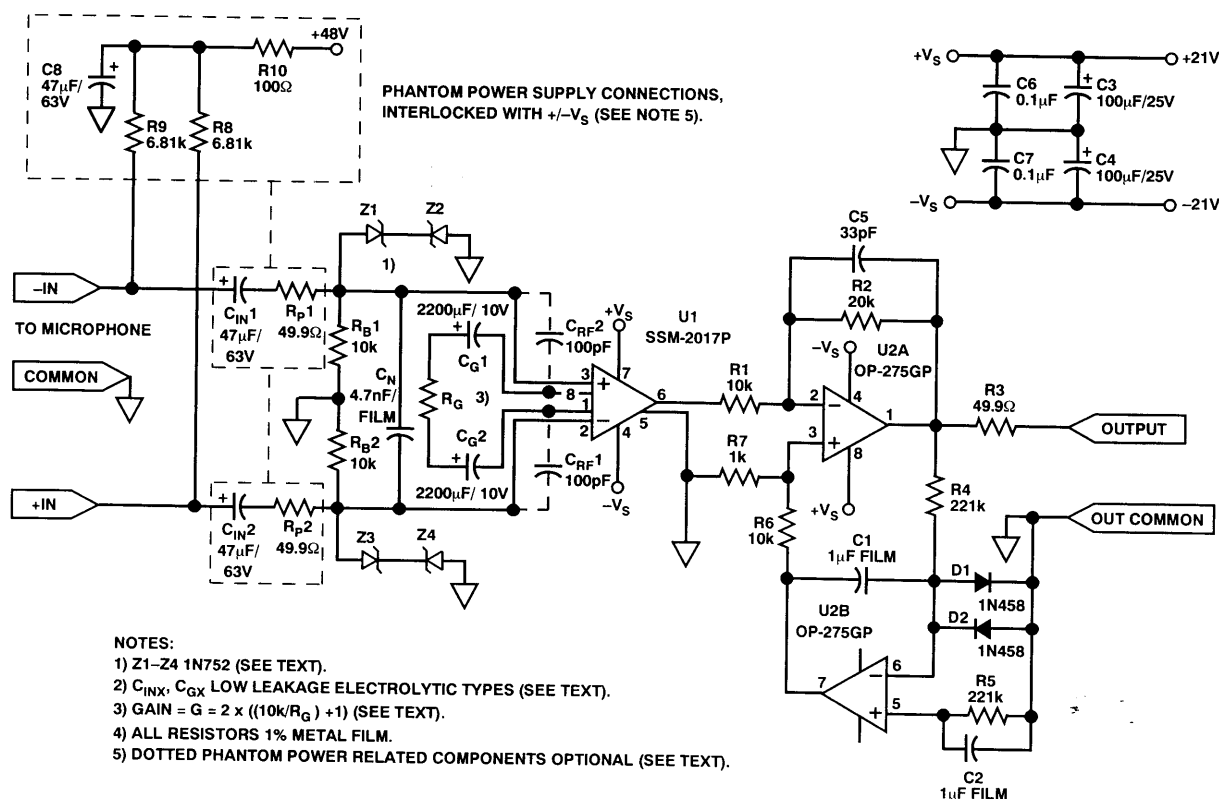

Figure 1. Low Noise Microphone Preamp

The Analog Devices SSM-2017 differential input audio IC preamp is suitable for use in mic preamps, and has the requisite low input voltage noise, plus high CM rejection and low distortion. Gain of this 8-pin IC is set via one external resistor, “ R_G ,” and is basically adjustable over a range of 1–1000 times (0 dB to 60 dB). Differential inputs at Pins 2–3 allow balanced mode input signals, and a single-ended output signal appears between the ICs output (6) and reference (5) terminals. The SSM-2017 architecture is similar to family predecessors SSM-2015/SSM-2016, but without access to the internal gain resistors (a constraint of the 8-pin package).

COMBINED IC AMPLIFIER IS SYNERGISTIC

Figure 1 is an example of a low noise microphone preamp along these lines, using the best advantages of a SSM-2017P IC combined with an OP-275GP dual bipolar/JFET low noise op amp. As shown, the circuit is a variable gain microphone preamp with an optional phantom power feature, but the circuit flexibility can also allow it to operate more generally. The SSM-2017’s strengths lie in low noise and distortion, and gain flexibility/simplicity. Rated only for 2 k or higher loads however, this makes driving 600 Ω loads somewhat limited with the basic IC. The circuit used here works by combining the virtues of two ICs into one single useful structure.

The SSM-2017 is used here to best advantage in a programmable gain input stage, which is then combined with a fixed gain, high current output buffer and dc servo stage using the OP-275. The OP-275 output buffer provides low distortion, high level drive into 600 Ω loads, with the second half of the dual IC employed as a servo to control output dc offset. The buffer stage U2A is operated at a modest gain of 2 times, keeping the required output swing of the SSM-2017 to a minimum, and the overall distortion low.

DESIGN FACTORS

The circuit uses the SSM-2017 first stage U1 as a gain programmable preamp block, with gain set by resistance R_G . In addition, the gain of stage two is fixed at –2, so the overall preamp gain “G” is then:

$$G = 2 \times \left(\frac{10\text{ k}}{R_G} + 1 \right) \quad (1)$$

In practice, R_G can be either a pot, or a switch controlled resistance used as a gain control for the entire circuit (with a minimum gain of 2) as:

$$R_G = \frac{20\text{ k}}{(G-2)} \quad (2)$$

For convenience, a table of R_G values for various gains is provided, using the closest standard 1% values. Since the circuit is likely to be used with R_G either switch selected or a reverse log taper pot, electrolytic decoupling capacitors C_{G1} and C_{G2} are used with R_G . This operates the U1 stage at a dc gain of unity, and prevents noise injection or thumps due to operating gain changes

(the gain Pins 1 and 8 of the SSM-2017 bias about 0.6 V below common, which provides a bias to these capacitors).

Table I. Gain Table

G	Gain		R_G (Ω)*
		dB	
2		6	Open
4		12	10 k
10		20	2.49 k*
20		26	1.1 k*
31.6		30	681*
40		32	523*
100		40	205*
200		46	100*
316		50	63.4*
400		56	49.9*
1000		60	20*
2000		66	10*

* R_G is rounded to closest 1% value where noted.

If overall gains greater than 66 dB are needed, the second stage gain can be increased by lowering R1. A 5 k value for example provides a maximum gain of 72 dB, and generally 6 dB more over the gain ranges of R_G .

PHANTOM POWER AND PROTECTION

With a phantom powered microphone in use, the “+IN” and “–IN” pins of the mic connector will see a large CM dc voltage. Dependent upon the particular mic in use and the power drain, this voltage can be in the range of 10–48 V dc, and upon it is superimposed the balanced audio signal. In normal operation, capacitors C_{IN1} and C_{IN2} decouple the dc level, and pass the audio signal to U1.

When the phantom power source is switched on/off, or the microphone cable is plugged in/out, potentially destructive transients of up to ± 48 V can be coupled through C_{IN1} and C_{IN2} , and will appear across R_{B1} and/or R_{B2} . If these spikes are not properly controlled and safely dissipated, they can cause destruction of the amplifier, U1. Note that this is true for *virtually any amplifier input stage, not just the SSM-2017*, as the stored energy in the coupling capacitors can develop peak discharge currents of several amperes if not limited by some means. In this circuit, CM voltage limiting is used on each of the differential input lines. This is done with pairs of back-to-back low voltage Zeners, Z1–Z2 and Z3–Z4. These are standard 1N752, 400 mW, $V_Z = 5.6$ V units from the “1N75x” series (equivalent to BZX79 series in Europe), and are effective in safely limiting the peak voltage of the discharge to 10 V or less. In addition, peak current limiting for transient discharge is provided by the series protection resistors, R_{P1} and R_{P2} . In dissipating the transient safely, the peak current must be limited to a level which will not cause failure of the protective Zeners, thus this resistance is necessary.

While the series resistances do add some noise over that of the amplifier used without them, it is mitigated in the fact that it is necessary only with phantom powered capacitive microphones (and can be switched out when not needed). Since these microphone types tend to be higher in output, this minimizes the degree of S/N degradation. More importantly, from a reliability point, a safe upper bound on the fault current is established, 1A or less in the case of a direct short to ground on a input line with a full 48 V supply (worst case).

As noted, the preamp circuit can be operated with or without the phantom power, so it is logical to optimize input connections so that those portions not absolutely essential for phantom power are not in the signal path when it is not in use, as well as the 48 V dc power itself being switched off. This would provide a means of switching R_{P1} and R_{P2} out when operating without phantom power, so that lowest noise performance is retained for other sources.

A further step which will aid in controlling transients is to interlock the 48 V supply with the bipolar power supply feeding the amplifier. This prevents switching on phantom power with the amplifier circuitry powered down, which would otherwise definitely invite trouble. However, with dc power applied to the amplifier, the protection is such that the phantom power supply can be switched on/off at will.

These protection part values and types have been lab tested, and represent a conservative balance between adequate fault protection and minimal degradation of the basic audio signal handling when phantom power is used. Other Zeners from the "1N75x" series can work for Z1–Z4, but they should be restricted to lower voltages (7.5 V or less). From a view of simply adequate protection, higher wattage types such as 1N47xx (1W) and 1N53xx (5W) families also absorb the transients, but do not appear to be fundamentally necessary.

The higher wattage Zener families have excessive non-linear capacitance, which can produce distortion, and thus for this reason they are not recommended. For example, the "1N75x" series diodes measured about 160 pF of capacitance, while the highest distortion measurements (not shown) on all three diode families show below 0.01% with a 1 V rms level to the preamp, with the higher capacitance devices showing slightly higher distortion, 0.0097 versus 0.0075%.

The complete preamp with protection was exercised with a pair of 0.1 Ω power MOSFET switches driving the input lines, with a higher value of coupling capacitance (100 μ F in lieu of 47 μ F). It survived this torture test, still measuring THD+N below 0.008%. From this it would appear that there is some latitude for variation of coupling capacitor size and the protection resistance. While slightly smaller protection resistances down to about 30 Ω can likely be used, large value changes here should be reverified from a protection aspect.

RFI

While not directly related to the dc transient problem, another source of potential problems with high gain preamps is radio frequency interference (RFI). In this circuit the input capacitor C_N filters high frequencies above 135 kHz before they reach the preamp input. In addition, further filtering is provided in the second stage by R2–C5, at 241 kHz.

Additional RFI filtering can take on several forms, separately or in combination. Separate low DCR in-line RF chokes can be added in series with the two inputs, or a single common-mode choke or low-pass filter, available as packaged assemblies. Consideration should be given in such cases to nonlinear effects in the inductor cores, as well as the nonlinear C/V characteristics of the RF quality bypass capacitors used. For example, high-K disc ceramics are excellent for RF applications, but are nonlinear with applied voltage. In this regard a better choice would be either NPO ceramic or stacked film polyester types. RF bypassing of the SSM-2017 input transistors can also be used, from Pins 1–2 and 3–8, as described on the AD625 data sheet.^{2, 3} This option is shown on the schematic as C_{RF1} and C_{RF2} .

Other input interface schemes to U1 can be used for connections to high level sources, in which case the (dotted) phantom power circuitry and the mentioned redundant circuitry can be deleted.

OUTPUT CONTROL

In the output stage, dc servo stage U2B senses the dc from U2A and compares it to a common reference point. U2B is an inverting integrator with an overall low frequency rolloff of about 0.12 Hz. With this servo loop operating, the net output dc offset will be essentially the sum of the voltage offset of U2B, and the offset current errors, and will be independent of the output dc offset of U1. With 1% values used for R4 and R5, the circuit's overall dc offset should typically be about 2 mV. For lowest integration errors, film capacitors should be used for C1 and C2, such as polycarbonate or polyester types. Diodes D1 and D2 provide protective clamping for U2B.

PERFORMANCE

This amplifier's performance is quite good over programmed gain ranges of 2–2000. For a typical audio load of 600 Ω , THD+N at various gains and an output level of 10 V rms is shown in Figure 2 (these tests results do *not* show the effects of the protection components, but as noted, these produced relatively small distortion degradations). For all but the very highest gain the THD+N is consistent and well below 0.01%, while the gain of 2000 becomes more limited by noise.

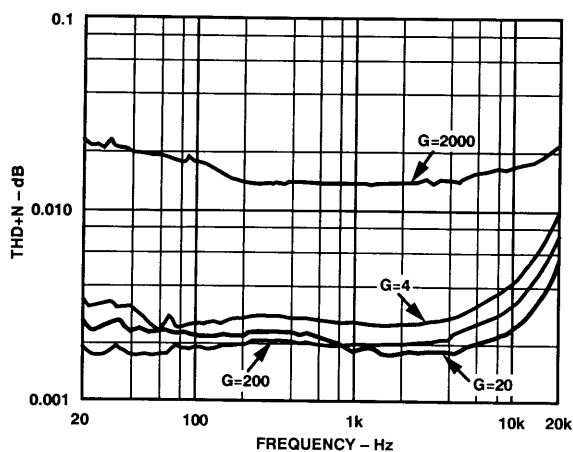
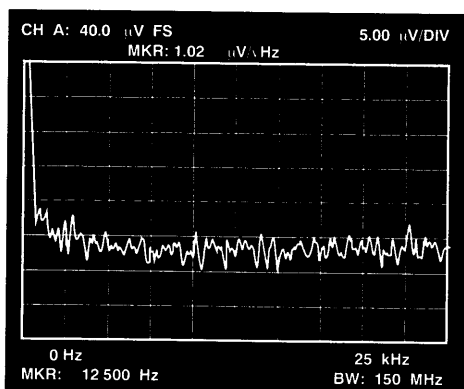

Figure 2. Low Noise Microphone Preamplifier THD+N Performance Various Gain ($V_{OUT} = 10\text{ V rms}$, $R_L = 600\ \Omega$)

Noise performance of the preamp circuit is exceptional, and is illustrated in Figure 3. This photo is a linear sweep spectrum analyzer plot over a range of 0 kHz–25 kHz. The operating gain of the preamp is 1000, so a displayed vertical scale factor of $1\ \mu\text{V}/\sqrt{\text{Hz}}$ is equivalent to $1\ \text{nV}/\sqrt{\text{Hz}}$, referred to the preamp input. In this photo the noise level is displayed at about $12.5\ \mu\text{V}$, which when divided by $\sqrt{150}$ (to account for the 150 Hz analyzer bandwidth) is a noise level of about $1\ \text{nV}/\sqrt{\text{Hz}}$ (to refer the $12.5\ \mu\text{V}$ displayed noise to the preamp input, divide by $\sqrt{150} \times 1000$, or 12,250).



CONDITIONS:
SSM-2017 GAIN = -500; OP-275 GAIN = -2
TOTAL GAIN = 1000
 $V_S = \pm 20\text{V}$; $R_L / C_L = 1\text{M}\Omega / < 60\text{pF}$

Figure 3. Noise Performance of Two-IC Preamp

Maximum output drive will be a function of the power supplies, and can be as high as 10 V rms, with higher voltage supplies. Note that output resistor R3 will limit the swing available when driving 600 Ω , but should be retained for short circuit protection. Supply voltages on the order of $\pm 20\text{ V}$ are appropriate for highest output into 600 Ω , but the circuit can also be operated on lower supply voltages with less output.

SOME PRACTICAL NOTES

To get the most from this circuit, appropriate quality components should be used. This is most critical for the electrolytic coupling capacitors, which preferably should have a low leakage specification (such as 0.002CV or less). One type identified with this characteristic was the Panasonic "HF,"⁴ with which the circuit was tested. This type is currently being phased out, so alternates should be considered (for example types "HFQ" or "HFE"). Values should be in the range of 22 μF –56 μF , with a voltage rating of 63 V–100 V or more (higher voltage ratings will aid in controlling leakage).

If desired, these can also be bypassed with small film capacitors to control high frequency resonances. Metal film types are recommended for all signal path resistors. Physical construction is important also, that is a neat, compact layout for the circuit board should be used. In particular, attention to lead dress and layout around the inputs to U1 will be important for minimum noise pickup. Some types of input coupling capacitors necessary for phantom power operation are physically large, and so are susceptible to noise pickup. Guarding and screening around these and the other sensitive nodes at the input will pay off with good performance. Finally, well regulated power supplies should be used, well bypassed with large electrolytics returned to the output common point.

ACKNOWLEDGMENTS

In preparing this article the authors appreciated the support of James Wong and Dan Parks, and comments from SSM-2017 designer Derek Bowers, all of the Analog Devices PMI division. Helpful comments also came from Chas Brooke of BSS Audio Ltd., Ben Duncan of Ben Duncan Research, David Josephson of Josephson Engineering, and Gordon Kapes of Studio Technologies.

REFERENCES

- ¹"ANSI Standard 268-15 (Revision 1987, amendments 1989, 1990, 1991)." American National Standards Institute, 11 W. 42nd St., New York, NY 10036.
- ²"Other Considerations (RFI Protection)," *AD625 Instrumentation Amplifier Data Sheet*.
- ³W. Kester, *1993 System Applications Guide*, Analog Devices, 1993, Chapter 1, pp 37–55.
- ⁴*Panasonic 91/92 Electrolytic Capacitor Catalog*, Panasonic Industrial Co., 2 Panasonic Way, Secaucus, NJ 07094.